

3E[®]

SHREDDING EQUIPMENT CHINA 3E

撕碎设备 中国 3E



简易回收线

单轴撕碎机+破碎机

Plastic Crushing Recycling Line

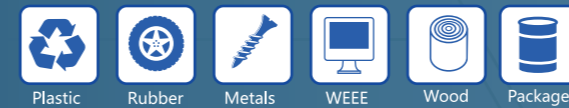

GRANULATOR 破碎机

3E[®]
MACHINERY
Waste Solutions



Domestic sales
国内销售热线Tel:86-(0)20-39960299

Overseas sales
海外销售热线Tel:86-(0)20-84729983

2024年3月印刷

广州市联冠机械有限公司 GUANGZHOU 3E MACHINERY CO.,LTD

Website: www.3e-machinery.com / www.3e-recycling.com

中国·广州市番禺区大龙街泰安路西六横街4号 NO.4 XI LIU HENG STREET,TAIAN ROAD,DALONG,PANYU DISTRICT,GUANGZHOU,CHINA



3E机械官网



公司微信

高效·经济·环保的破碎机 EFFICIENT ECONOMICAL ENVIRONMENTALLY

3E机械专注“破碎”与环保回收行业，我们专业设计，制造与销售破碎机，同时可根据客户的需求提供完整的工业废料回收解决方案。

3E Machinery is an integrated company specialized in developing, manufacture, distributing and providing recycling machinery solutions. We focus on "Shredding" and "Recycling" industry. As per customer's requirements, 3E could provide complete recycling solutions.

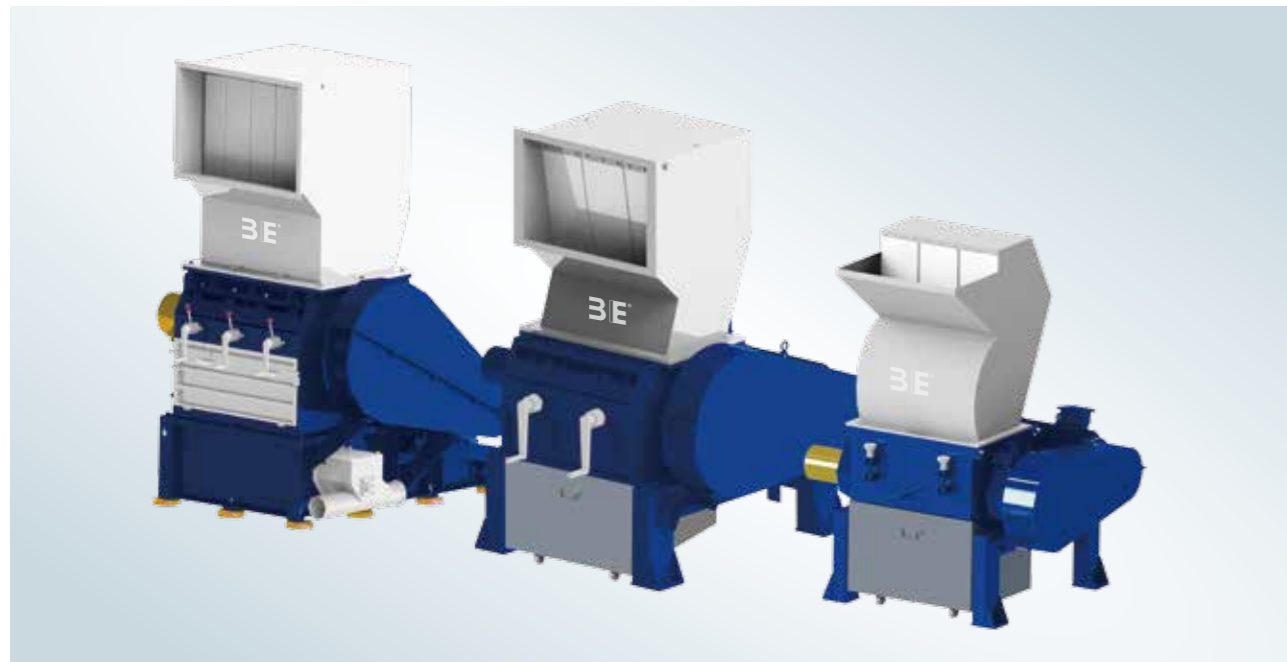

PC系列破碎机主要用于塑料、金属、纸张、电子垃圾、橡胶、轮胎等物料的破碎，破碎物的外形可以是块状胶头料，薄膜，片材，管状、浇口料及各种外形的中空容器等。客户可针对不同物料的破碎需求选用不同的刀辊结构，从而提高效能。同时客户可根据需求配备风送集料装置和隔音罩。此系列破碎的箱体为对开结构，清洗、换刀、维修保养十分方便，具有经济适用，操作简易，使用寿命长等优点。

The PC series granulators are used for crushing plastic, metal, paper, electronic waste, rubber and tires. The shape of the crushing material is different that includes plastic lump, film, sheet, pipe or various shape hollow containers etc.

In order to improve the efficiency, recycling different material adopt different rotor for the machine. The material is cut cleanly between the rotor and stator knives, and cut down to a homogenous regrind size determined by the screen holes on the fitted screen. At the same time, it could equip with bagging off unit and sound proof cover for the machine based on the customer's requirements. It is split structure for the cutting chamber, so it is easy for cleaning, replacing blade, maintaining and repairing.

应用 | APPLICATION



- 胶头料/高强度工程塑料
Hard Plastic
Plastic Lump (Purging)/Plastic Blocks/Engineering plastics: ABS, PC, PS



- HDPE瓶 HDPE bottle
牛奶瓶 Milk bottle

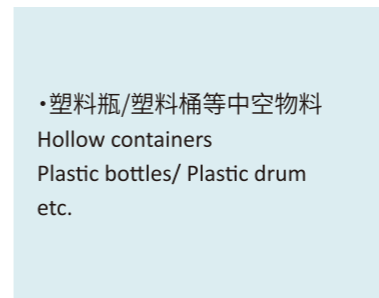

- 塑料瓶/塑料桶等中空物料
Hollow containers
Plastic bottles/ Plastic drum etc.



- IBC桶
IBC tank



- 薄膜/吨袋/编织袋/PET打包带
Soft Plastic
Plastic Films/Woven bags/ PET strapping



- 大蓝桶 Plastic barrels



- 塑料筐 Plastic crates

Key Feature | 特点

刀辊机械固定&外置轴承 Rotor locking device & external bearing

刀辊机械固定：箱体打开同时，通过插销把刀辊固定，避免刀辊转动对人员造成伤害。

Rotor Locking Device: Ensures safety during maintenance when the hopper is in the open position.

外置轴承：有效避免物料中含有的水分和粉尘进入轴承

External bearing: External spherical rotor bearings with protective bearing covers prevents foreign objects entering the bearing housing.



筛网 | Screens

不同的筛网尺寸和形状，符合客户对出料的不同需求。

A wide range of screens available to adjust the particle size of discharge materials.

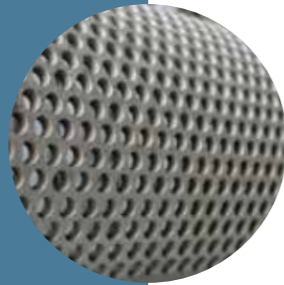

螺旋出料 Optional Screw Discharge Chute

破碎后的物料通过螺旋输送自动出料，以保证机器的连续生产。

Material can be discharged from the collection chute by screw feed rather than air extraction.



进料斗 | Hopper

加固设计，坚实耐用。

Robust welded hopper with additional support struts to increase strength of hopper and prolong service life.



在线破碎料斗 | Hopper



CE认证 | CE Certified

机械、电器多重保护，符合欧盟CE标准
Safety devices in line with European CE Certification.



筛网锁紧装置 Lockable Screen Support Frame (screen locking device)

通过多个锁紧螺栓锁紧筛网，操作方便，牢固可靠。

Robust frame to support the screen maintains the screen shape and avoids damage to the screen.



液压开斗装置 Hydraulic Chamber Opening Mechanism

通过液压控制料斗和箱体的打开合并，安全平稳。
It will be more safety to open the hopper and cutting chamber by hydraulic station.



隔音罩 | Sound Proof

能有效隔绝机器设备在运作过程中向外辐射的噪音
Cut off the noise effectively when the machine operation.



刀辊 | Rotor Variations

客户可根据对不同物料破碎的需求,选择不同的刀辊结构,可最大程度提高破碎产量和质量,同时可以延长设备的使用寿命。It could improve the capacity and quality largely and extend the service life for the blade by using different rotor for different recycled material.

▶ 阶梯刀刀辊 Ladder Blade Rotor



阶梯刀辊采用实心刀体结构,适合破碎极坚硬材质物料,如胶头料、厚壁管、厚板等物料。

The ladder blade rotor uses a staggered blade configuration which offers high inertia and limits the amount of impact on each blade. The structure for the rotor is solid. It is used normally for processing hard/thick materials such as thick pipe, board and plastic lumps

▶ 瓶片刀刀辊 P-Rotor



此刀辊采用多组错开一定角度的后置人字刀排布,减少切削冲击力,适合用于破碎薄壁物料,如PET瓶等。

The P-Rotor blades are placed on the rotor with stagger angle reducing the impact during operation. Specifically designed for processing flexible materials such PET bottle.

▶ PCK 刀辊 PCK-Rotor



此刀辊的开口尺寸较大,适用于大尺寸,中空型物料的破碎。

The gap between the blades are larger enough which is easier for cutting material and it is suitable to process large size empty material.

▶ 前置人字刀辊 Front Set V-Rotor



前置人字刀辊整体强度更好,适合破碎薄膜,水口料, PVC 管材和厚片材等物料。

The front set V rotor has more strength rotor, it is suitable for crushing film, injection plastics, PVC pipe, thick sheet etc.

▶ 后置人字刀普通型刀辊 Rear Set V-Rotor



后置人字刀辊布置有利于物料进入切削位,提高切削效率,适合破碎片材,薄膜等物料。

The rear set V-rotor is similar in design to the front set V-rotor with the rotor blades set at an inclined angle, it is particularly suitable for processing lighter materials. The opening between the blade is large. It is suitable for crushing hollow material such as PVC sheet, film etc.

▶ 后置人字刀整体刀辊 Rear Set L-Rotor



此刀辊全密封设计,可通冷却水,适合易发热物料的粉碎。

The gap between rotor and blade is large enough, and it could crush the material in short time.. It is suitable to crushing rubber.

The space between the blades is bigger, that made the rotor touching the materials quickly. With multi-hooks blades, the cutting efficiency is high. Suitable for crushing materials such as rubber.

中小型破碎机 SMALL & MEDIUM GRANULATOR

PC26-PC42属于常用的中小型破碎机，此系列破碎机用途广泛，经济适用性强，适用于破碎各种塑料、机头料、胶头料、片材、电路板、薄膜、橡胶等，同时适用于塑料瓶、管材等中空物料的破碎。客户可根据不同物料的破碎需求，选择不同的刀辊结构，提高破碎效率和破碎效果，也可按需配备风送集料装置和隔音结构。具有实用性强、操作简便、使用寿命长等特点。

The PC26-PC42 range of Granulators is our conventional range of small to medium size Granulators. The body of the machine is made of welded by rigid steel structure. Suitable for processing a wide range of materials including: plastic lump, sheet, plastic film, rubber, etc.

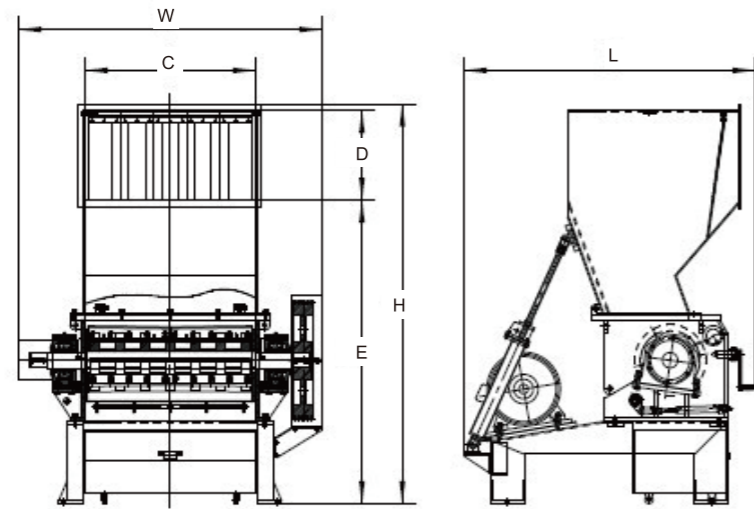

Item	Model	PC2660	PC3260	PC3280	PC4280	PC42100	PC42120
外形尺寸 Dimension L/W/H(mm)		1483×1328×1740	1486×1368×1711	1586×1568×1814	1770×1642×2425	1770×1842×2425	1760×2221×2530
粉碎室尺寸 Cutting chamber C/D(mm)		634×383	634×415	834×414	834×540	1034×540	1234×540
破碎口高度 E(mm)		1567	1269	1369	1842	1842	1947
刀体回转直径 Rotor Diameter(mm)		φ260	φ320	φ320	φ420	φ420	φ420
主轴转速 Main Shaft Speed(r/min)		591	438	627	466	466	462
筛网孔径 Screen Mesh(mm)		φ8	φ12	φ12	φ12	φ12	φ12
动刀数量 Rotor-knives(PCS)		3×2	3×2	3×2	3×2	3×2	3×2
定刀数量 Stator-knives(PCS)		2X2	2×2	2X2	2X2	2X2	2X2
主机功率 Main Motor Power(KW)		15	15	22	37	45	55
设备重量 Weight(KG)		Approx 1000	Approx 1500	Approx 1700	Approx 2600	Approx 3500	Approx 4500

重型破碎机 HEAVY-DUTY GRANULATOR

PC52-PC80系列属于大型破碎机，采用牢固焊接钢结构，是专门针对难碎物料而设计的通用重型设备。适用于破碎型材、管材、大块实心物料以及注膜过程中产生的废料等。客户可根据不同的出料要求，选择不同尺寸的筛网。具有实用性强，操作简易等特点。

The PC52-PC80 range of granulators is our large range of granulators, it is design for recycling the hard and thickness materials, such as proximate matter, tubes, large size solid materials, defective products etc.

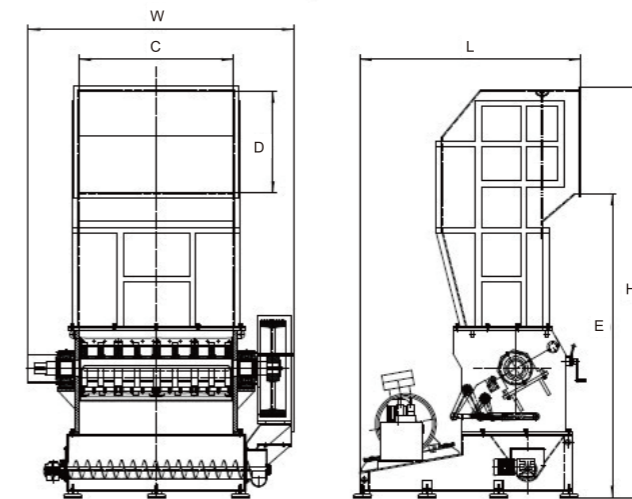

Item	Model	PC52100	PC52120	PC66120	PC66160
外形尺寸 Dimension L/W/H(mm)		2119 X 2025 X 2984	2070 X 2225 X 2984	2410 X 2320 X 4340	2335 X 2808 X 4337
粉碎室尺寸 Cutting chamber C/D(mm)		1034 X 708	1234 X 705	1234 X 1080	1634 X 1008
破碎口高度 E(mm)		2236	2236	3214	3214
刀体回转直径 Rotor Diameter(mm)		φ520	φ520	φ660	φ660
主轴转速 Main Shaft Speed(r/min)		462	462	462	414
筛网孔径 Screen Mesh(mm)		φ12	φ12	φ12	φ12
动刀数量 Rotor-knives(PCS)		5*2	5*2	5*2	5*4
定刀数量 Stator-knives(PCS)		2 X 2 / 2 X 3	2 X 2 / 2 X 3	2 X 2 / 2 X 3	4 X 2 / 4 X 3
主机功率 Main Motor Power(KW)		55	75	90	132
设备重量 Weight(KG)		Approx 5000	Approx 6000	Approx 7500	Approx 8800

Item	Model	PC80160	PC80200	PC80240
外形尺寸 Dimension L/W/H(mm)		3000 X 2900 X 4763	2735 X 3373 X 4563	3979 X 3070 X 4479
粉碎室尺寸 Cutting chamber C/D(mm)		1634 X 1000	2033 X 1000	2434 X 1000
破碎口高度 E(mm)		3675	3514	3351
刀体回转直径 Rotor Diameter(mm)		φ800	φ800	φ800
主轴转速 Main Shaft Speed(r/min)		414	420	417
筛网孔径 Screen Mesh(mm)		φ12	φ12	φ12
动刀数量 Rotor-knives(PCS)		7*4	9*4	9*6
定刀数量 Stator-knives(PCS)		4 X 2 / 4 X 3	4 X 2 / 4 X 3	6 X 2 / 6 X 3
主机功率 Main Motor Power(KW)		160 / 200	160 / 200	160 X 2
设备重量 Weight(KG)		Approx 15000	Approx 18000	Approx 21000

K系列破碎机 K SERIES GRANULATOR

K系列刀辊的开口尺寸较大,适用于大尺寸,塑料中空容器的破碎,例如转运筐,塑料桶等。

K Rotor with big opening between the blades, it is suitable for crushing large size and plastic hollow containers, like crates, barrels etc.

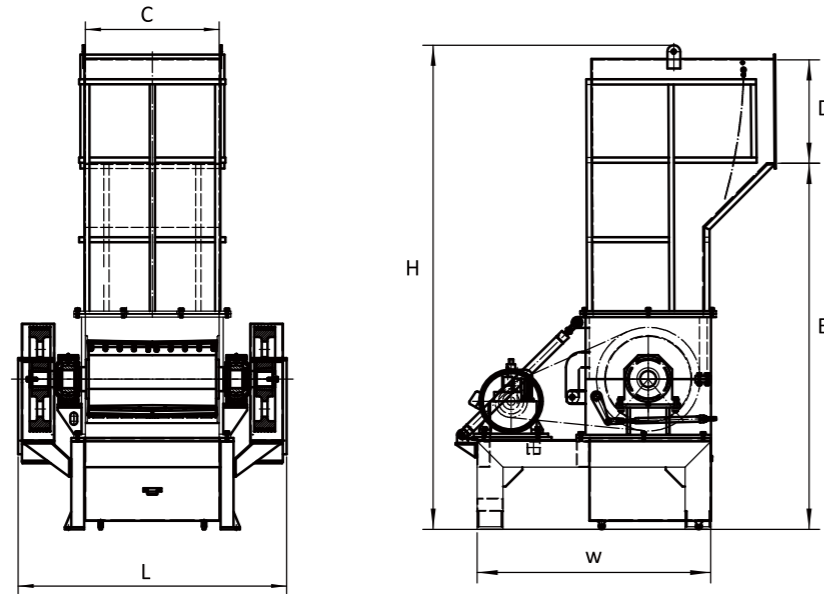

Item	Model	PCK4280	PCK52120	PCK66100	PCK66160	PCK80130
外形尺寸 Dimension L/W/H(mm)		1758X1642X2435	1656X1700X2448	1805X2074X3740	1805X2674X3740	2495X2706X2483
粉碎室尺寸 Cutting chamber C/D(mm)		620X834	625X1200	850X1034	850X1634	1010X1334
破碎口高度 E(mm)		1845	1995	2827	2827	3150
刀体回转直径 Rotor Diameter(mm)		φ420	φ520	φ660	φ660	φ800
主轴转速 Main Shaft Speed(r/min)		467	572	462	462	417
筛网孔径 Screen Mesh(mm)		φ12	φ12	φ12	φ12	φ12
动刀数量 Rotor-knives(PCS)		6	6	6	12	6
定刀数量 Stator-knives(PCS)		4	4	4	8	4
主机功率 Main Motor Power(KW)		37	55	75	110	110
设备重量 Weight(KG)		Approx 2700	Approx 6000	Approx 7800	Approx 8800	Approx 12000

E系列破碎机 E SERIES GRANULATOR

PC经济型破碎机主要适用于普通塑料的破碎,通过适应性刀辊设计可适用于PE/PP薄膜,小中空塑料(PET瓶和HDPE瓶)等,具有坚固耐用,结构简单,实用性强,操作维护简便以及性价比高。

The PC economical crusher is mainly suitable for crushing common plastics , PE / PP film, small hollow plastic (PET bottle and HDPE bottle), etc., with simple structure, strong practicability, simple operation and maintenance and high cost performance.

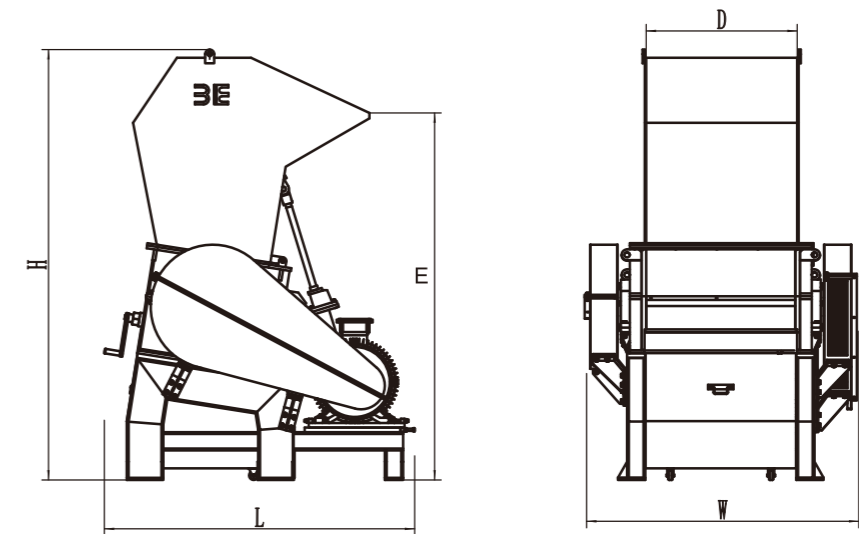

Item	Model	PC5280E	PC52120E	PC52160E
外形尺寸 Dimension L/W/H(mm)		1656X1550X2448	1656 X 1700 X 2448	1656 X 2100 X 2448
粉碎室尺寸 Cutting chamber (mm)		620X800	625 X 1200	625 X 1600
破碎口高度 E(mm)		1995	1995	1995
刀体回转直径 Rotor Diameter(mm)		φ520	φ520	φ520
主轴转速 Main Shaft Speed(r/min)		572	572	572
筛网孔径 Screen Mesh(mm)		φ12	φ12	φ12
动刀数量 Rotor-knives(PCS)		8	8	16
定刀数量 Stator-knives(PCS)		4	4	8
主机功率 Main Motor Power(KW)		45	55	90
设备重量 Weight(KG)		Approx 2000	Approx 2800	Approx 3500

锤片式破碎机 HAMMER MILL

锤片式破碎机是电池、极片、木材等物料回收生产线的核心部分。破碎机主机采用合金钢焊接去除应力处理，结构更紧凑，强度更高。箱体采用密布式强筋板，保证箱体具有足够的强刚度。刀片采用合金钢制作，具有较高的韧性和耐冲击性，保证耐磨性，具有劳动强度低，维护维修便利等特点，破碎效果好，堆积密度高，可作为一级/二级破碎设备使用。

Hammer Mill is an important part of the waste lithium batteries/electrode plate recycling line. Applying alloy steels welding for the main part of the crusher, the structure is more compact, the strength is higher and stress-relieve treatment. The cutting chamber is made by strong steel plate, therefore, it is strong and firm enough. The raw material of the blade is high manganese steel which has higher toughness and impact resistance and ensures abrasion resistance. Aiming at the hard shredding material, there is device for discharging. There are more features for this machine, such as low labor intensity, low maintenance costs ect. It is suitable for crushing scrap metal, for example, scrap steel, waste car shell and scrap iron products. For the output material, the density is average, effect is good and the bulk density is high.

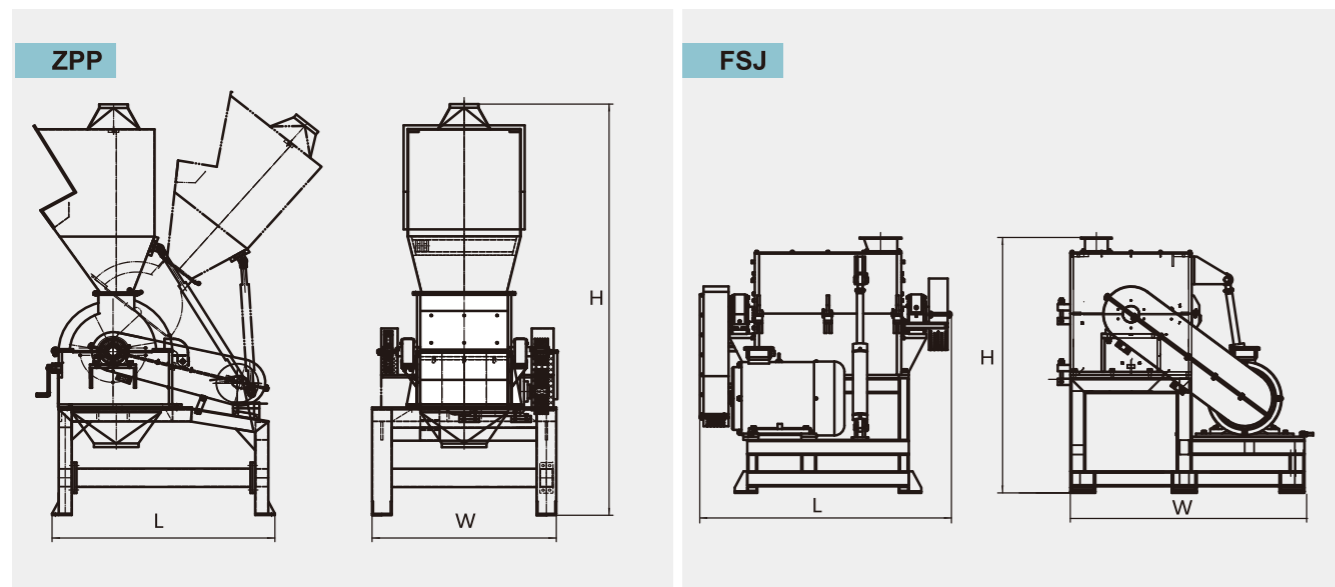

Item	Model ZPP6045	Model ZPP6065	Model ZPP8080	Model FSJ700
外形尺寸 Dimension L/W/H(mm)	1693 X 1200 X 3356	1693 X 1400 X 3356	2139 X 1700 X 4148	1827 X 2010 X 2040
入料口宽度 Width of cutting chamber(mm)	928	928	1200	978
刀体回转直径 Rotor diameter(mm)	φ600	φ600	φ800	φ700
主机功率 Main motor power(kw)	22	37	75	75
设备重量 Weight(kg)	Approx 4000	Approx 5500	Approx 7000	Approx 6500

废钢锤式破碎机 HAMMER MILL

锤式破碎机是废旧金属破碎回收生产线的核心部分。破碎机主机采用合金钢焊接去除应力处理，结构更紧凑，强度更高。箱体采用密布式强筋板，保证箱体具有足够的强刚度。刀片采用高锰钢制作，具有较高的韧性和耐冲击性，保证耐磨性，针对难碎物料设有排泄装置，具有劳动强度低，维护维修便利等特点。适用于破碎废钢、废旧汽车外壳、废旧铁制品等废旧金属，出料密度均匀，破碎效果好，堆积密度高。

Hammer Mill is an important part of the Waste Metal Recycling Line. Applying alloy steels welding for the main part of the crusher, the structure is more compact, the strength is higher and stress-relieve treatment. The cutting chamber is made by strong steel plate, therefore, it is strong and firm enough. The raw material of the blade is high manganese steel which has higher toughness and impact resistance and ensures abrasion resistance. Aiming at the hard shredding material, there is device for discharging. There are more features for this machine, such as low labor intensity, low maintenance costs ect. It is suitable for crushing scrap metal, for example, scrap steel, waste car shell and scrap iron products. For the output material, the density is average, effect is good and the bulk density is high.

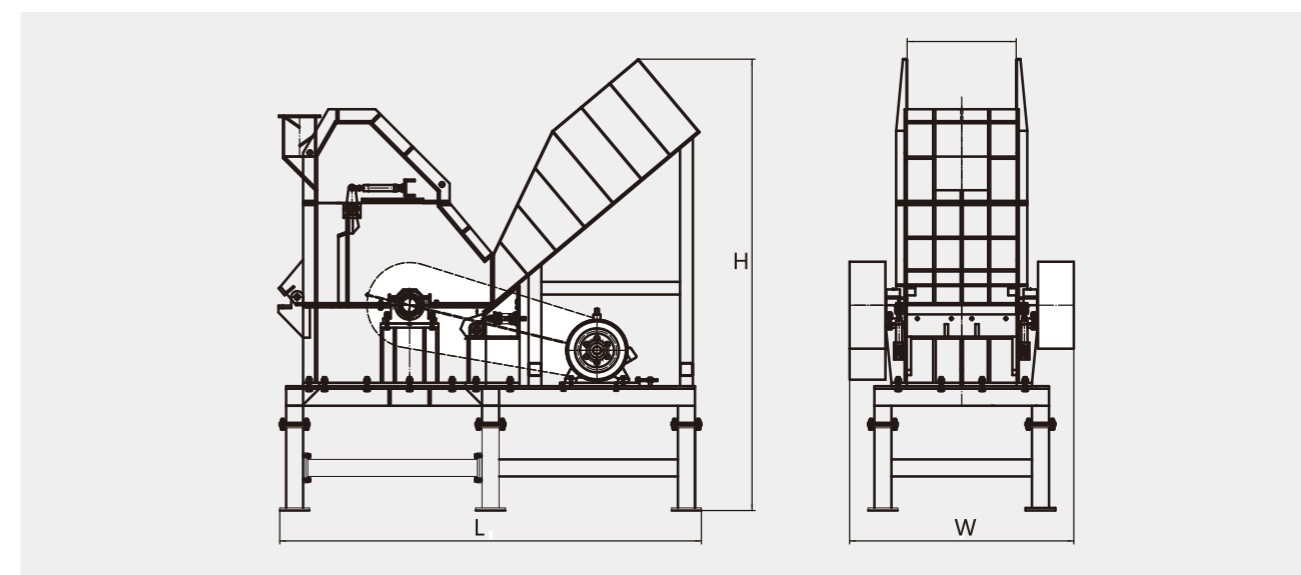

Item	Model ZP6045	Model ZP8080	Model ZP10080	Model ZP130120	Model ZP170160
外形尺寸 Dimension L/W/H(mm)	1740 X 1250 X 2200	2100 X 1700 X 3200	2650 X 2250 X 4250	4950 X 2650 X 5300	5320 X 3150 X 6200
入料口宽度 Width of cutting chamber(mm)	450	800	1000	1200	1600
刀体回转直径 Rotor diameter(mm)	φ600	φ800	φ1000	φ1300	φ1300
主机功率 Main motor power(kw)	30/37/45	55/75/90	132/160/185	200/250/280	315/355/400
锤头数量 Rotor-knives(pcs)	12	12	14	14	14
设备重量 Weight(kg)	Approx 2200	Approx 4100	Approx 7300	Approx 9300	Approx 11300

立式破碎机 VERTICAL GRANULATOR

立式破碎机主要用于厚度较薄、强度较低的金属材料或非金属脆性物料的破碎回收，如汽车外壳、冰箱外壳、电脑机箱等废旧物料，同时可适用于相对较大中空物料的破碎。经此机型破碎后的铁质物料更加密实，堆积密度大于1200 kg/m³，可满足客户对小尺寸大产量的出料的需求，同时设备可作为二级破碎设备使用。

The Vertical Granulator is design for recycling the thin and low strength metals or nonmetal brittleness materials. Suitable for crushing materials including: car shell, shell of WEEE, computer case and etc. The materials are broken is more dense, bulk density > 1200 kg/m³. Besides, this machine can be used as a secondary crushing equipment.

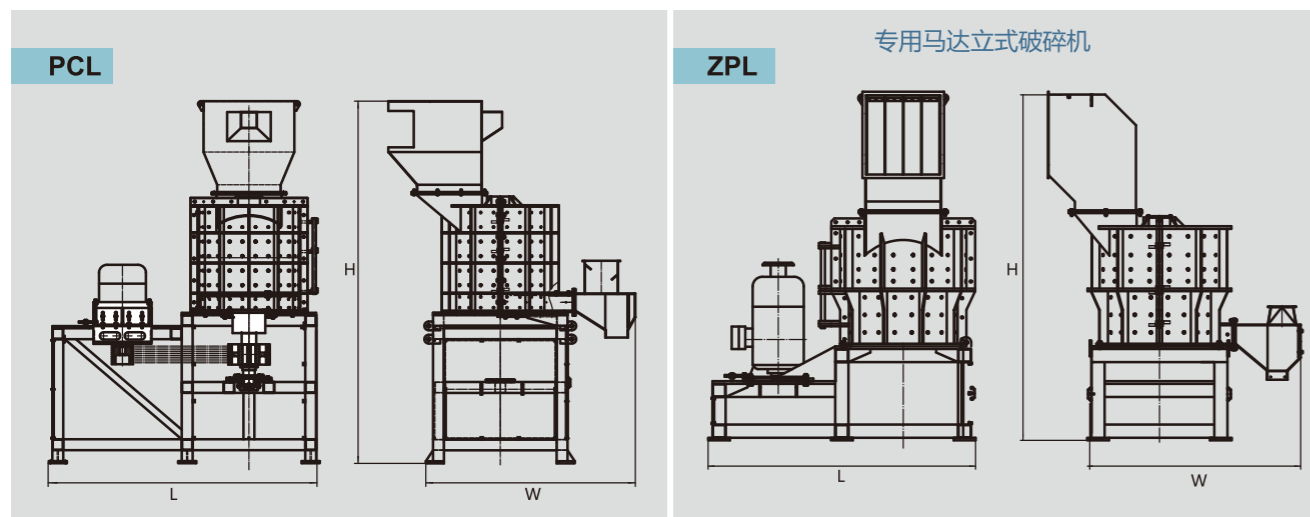

Model Item	PCL100	PCL200	PCL400	ZPL100
外形尺寸 Dimension L/W/H(mm)	3050 X 3036 X 4634	3730 X 3407 X 4984	4580 X 3200 X 6300	3050 X 2880 X 3980
破碎室高度 High Of The Cutting Chamber(mm)	819	835	950	1350
刀体回转直径 Rotor Diameter(mm)	φ990	φ1165	φ1400	φ1050
主机功率 Main Motor Power(kw)	75	132	320	132
设备重量 Weight(kg)	Approx 8000	Approx 13000	Approx 18000	Approx 8500

说明 NOTICE

以上规格参数仅供参考，如有更改恕不另行通知。请在订购前与我司销售代表确认。

The above specifications are only for reference and subject to change without prior notice, please confirm with our sales representative when making order.

应用案例 CASES



塑料简易破碎线
Plastic Crushing Recycling Line



小家电拆解回收处理生产线
Small home appliances Crushing Recycling Line

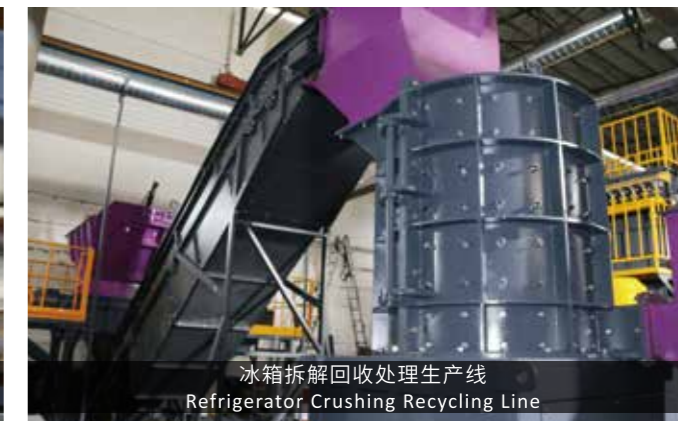

冰箱拆解回收处理生产线
Refrigerator Crushing Recycling Line